

PALCO 3 - PALCO 5

PROFESSIONAL
LED COLOURCHANGER

- GB
- I
- D
- F
- E
- P



Vi ringraziamo per aver acquistato un prodotto SGM.

Per ottenere i migliori risultati dal suo utilizzo, vi preghiamo di leggere attentamente questo manuale di istruzioni. Al suo interno troverete le informazioni tecniche e le specifiche d'uso del prodotto. Nelle pagine in appendice troverete inoltre schemi e diagrammi destinati all'assistenza tecnica.

Nell'ottica di qualità SGM, è possibile che l'Azienda apporti migliorie ai suoi prodotti, per cui consigliamo di allegare il manuale al prodotto stesso e di trascrivere il numero di serie nell'ultima pagina della copertina: utilizzando il presente manuale con un apparecchio fabbricato prima o dopo la sua stampa, potrebbero esserci discrepanze fra l'apparecchio e quanto riportato nel Manuel stesso.



Thank you for buying an SGM product.

To obtain the best results, please carefully read this instruction manual in which you will find technical information and specifications for use of the product, as well as diagrams for technical service in the appendix.

In light of SGM quality, the company may make improvements to its products. Therefore, we recommend that the manual be attached to the product and the serial number copied onto the back cover: using this manual with equipment manufactured before or after its printing, might show discrepancies between the equipment and the information listed in the manual.

Wir danken Ihnen für den Kauf eines Produkts von SGM.

Zur Erzielung der besten Resultate bei der Benutzung bitten wir Sie, die vorliegende Bedienungsanleitung aufmerksam zu lesen. Darin finden Sie die technischen Informationen sowie die Anweisungen für die Benutzung des Produkts. Im Anhang befinden sich außerdem die Schaltpläne und Diagramme für den Kundendienst.

SGM behält sich das Recht vor, Verbesserungen an den Produkten vorzunehmen und deshalb empfehlen wir, die Bedienungsanleitung dem Produkt stets beizulegen und die Seriennummer auf der letzten Seite des Umschlages einzutragen. Bei der Verwendung dieses Handbuchs mit einem Gerät, das vor oder nach der Drucklegung produziert wurde, können sich Abweichungen zwischen Gerät und dem Inhalt des Handbuchs ergeben.

Nous vous remercions d'avoir acheté un produit SGM.

Pour optimiser son utilisation, nous vous prions de bien vouloir lire attentivement cette notice où vous trouverez les informations techniques et les caractéristiques d'utilisation du produit. En outre, vous trouverez également, dans les pages en appendice, les schémas et les diagrammes concernant l'assistance technique.

Le concept de qualité SGM, lui permet d'améliorer continuellement ses produits et c'est pourquoi nous vous conseillons de joindre la notice au produit et d'inscrire le numéro de série sur la page de couverture. En effet, si on l'utilise avec un appareil fabriqué avant ou après son impression, il peut y avoir des différences entre l'appareil et ce qui figure dans la notice.

Les estamos sumamente agradecidos por haber elegido un producto SGM.

Para obtener los mejores resultados, les rogamos leer detenidamente el presente manual de instrucciones. El mismo contiene las informaciones técnicas y las indicaciones de uso del producto. Las páginas anexas contienen además los esquemas y diagramas necesarios para la asistencia técnica.

Para mantener la calidad SGM, es posible que la Empresa aporte mejoras sus productos, por ello les aconsejamos conservar el manual junto con el aparato correspondiente y escribir su número de serie en la última página del manual; si en cambio se utiliza el presente manual con un aparato frabricado antes o después de su impresión, es probable que existan discrepancias entre el aparato y las indicaciones del mismo.





Sommario

MANUAL SYMBOLS	3
CHANGES TO THIS MANUAL	3
SAFETY INFORMATION	4
ALWAYS INSIST ON ORIGINAL SPARE PARTS BEING FITTED <i>GENERAL WARRANTY CONDITIONS</i>	4
<i>GENERAL WARRANTY CONDITIONS</i>	5
1 INTRODUCTION	6
1.1 MAIN FEATURES	6
LEDs	6
LENSES	6
FUNCTIONS	6
CONTROL SIGNALS	7
MICROCOMPUTER	7
1.2 PALCO FUNCTIONS	7
USITT DMX 512	7
COOLING	7
COLOUR	7
LEDs	8
DIMMER	8
SHUTTER	8
MACRO	8
MEMORIES	8
DISPLAY	8
SOFTWARE UPDATE	8
1.3 MECHANICAL SPECIFICATIONS	9
1.4 ELECTRICAL SPECIFICATIONS	10
LENSES	10
LEDs	10
1.5 OPTIONAL ACCESSORIES	10
2 INSTALLATION	11
2.1 UNPACKING THE FIXTURE	11
2.2 MOUNTING THE FIXTURE	11
WIRING	11
INSTALLATION AND POSITIONING	12
ADDRESSING THE FIXTURE	14
3 OPERATION	17
3.1 CONTROLLING THE FIXTURE VIA DMX	17
DIMMER CHANNEL CH 2	17
RED CHANNEL CH 3	17
GREEN CHANNEL CH 4	17
BLUE CHANNEL CH 5	17
STROBE/SHUTTER CHANNEL CH 1	18
MACRO CHANNEL CH 7	19
COLOUR MODE CHANNEL CH 8	20
CTC CHANNEL CH 6	20
3.2 OPERATION	20
COLOURS	20
COLOUR TEMPERATURE	20
SHUTTER/STROBO	20
4 MICRO COMPUTER CONTROL	21
4.1 MICROCOMPUTER "CONTROL"	21
4.2 NAVIGATING THE MENU	21

4.3	STRUCTURE OF THE MENU	22
	ADDRESSING	24
	COLOUR BALANCE.....	24
	BALANCE.....	24
	BOOST	25
	ELAPSED TIME METER	25
	INPUT SIGNAL	25
	WIRELESS	26
	WIRELESS LOGOFF.....	26
	WIRELESS EXIT.....	26
	DISPLAY BRIGHTNESS.....	27
	INVERT DISPLAY	27
	DMX DELAY	27
	DAYS OF THE WEEK	27
	TIME	28
	SETTING DEFAULT PARAMETERS.....	28
	RESETTING DEFAULT PARAMETERS	28
	TEST FUNCTIONS.....	29
	TEMPERATURA	29
	CONFIGURING A MASTER.....	29
	CONFIGURING SLAVES.....	29
	ENABLING – DISABLING THE SCHEDULER.....	30
	INTERNAL PROGRAM PLAYBACK.....	30
	PROGRAMMER	30
	SCHEDULER.....	31
5	STAND-ALONE PROGRAMMING.....	32
5.1	PROGRAMMING PALCO	32
	STEP 1 - SCELTA CHOOSING THE PROGRAM NUMBER	32
	STEP 2 - CHOOSING THE SCENE NUMBER	33
	STEP 3 - CHOOSING THE FIXTURE NUMBER	33
	STEP 4 - SHUTTER	33
	STEP 5 - DIMMER.....	33
	STEP 6 – RED / WHITE1.....	33
	STEP 7 – GREEN / WHITE2.....	34
	STEP 8 – BLUE / AMBER	34
	STEP 9 – MACRO.....	34
	STEP 9 - SCENE TIME	34
	STEP 10 - FADE TIME.....	35
	STEP 11 - ENABLING SCENES	36
	STEP 12 - PROGRAM PLAYBACK.....	36
5.2	THE EVENT SCHEDULER	36
	STEP 1 - CHOOSING THE EVENT NUMBER	36
	STEP 2 - CHOOSING THE PROGRAM NUMBER	36
	STEP 3 - CHOOSING THE DAY	37
	STEP 4 - START TIME.....	37
	STEP 5 - END TIME.....	38
	STEP 6 - ENABLING AN EVENT	38
	STEP 7 - ENABLING THE SCHEDULER	38
6	MAINTENANCE	39
	ORDINARY MAINTENANCE.....	39
	SPECIAL MAINTENANCE	39
7	ACCESSORIES	40
7.1	INSTALLING OPTIONAL LENSES	40
	REMOVING THE FRONT LENS PANEL	40
	INSTALLING THE NEW FRONT LENS PANEL	42
	WIRELESS ANTENNA INSTALLATION FOR PALCO5.....	43

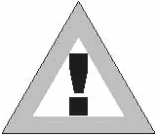
Manual symbols

This manual uses graphic symbols to emphasize any hazards during the operation work described.

	This symbol indicates a General hazard
	This symbol indicates electric shock risk
	This symbol indicates a hot surface risk
	This symbol indicates that the unit must not be laid on an inflammable surface or in any case must be kept away from naked flames

Changes to this manual

SGM has an on-going product development policy, so the information printed in this manual may not be completely up to date.



If any doubts arise regarding the topics covered in this manual or should any further help be required, our online services (internet-server www.sgm.it) are available 24 hours a day. In the FAQ section of the technical assistance zone, answers can be found to numerous common queries: fixtures, firmware and manuals can also be downloaded whenever required.

REVIEW	DATE	AUTHOR	DESCRIPTION
1.02	10/05/2007	SGM TECHNOLOGY FOR LIGHTING	DOCUMENTO INIZIALE

Safety information

Read the instructions in this manual carefully, as they give important instructions regarding installation, operation and maintenance safety.

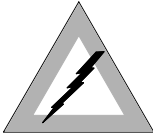
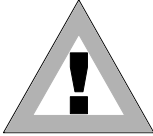
This manual must be kept with the fixture for future consultation. In the event of the fixture being sold or passed to another user, always make certain that the booklet is with the unit, to enable the new owner to be informed on its operation and relative care.

	<ul style="list-style-type: none"> ▪ UNIT NOT FOR HOME USE; ONLY FOR PROFESSIONAL USE. ▪ AFTER HAVING REMOVED THE PACKAGING, MAKE CERTAIN THE UNIT IS NOT DAMAGED IN ANY WAY. WHEN IN DOUBT, DO NOT USE THE UNIT, AND CONTACT AN AUTHORIZED SGM TECHNICAL ASSISTANCE CENTRE. ▪ THE VARIOUS PART OF THE PACKAGING (PLASTIC BAGS, POLYSTYRENE FOAM, NAILS, ETC.) MUST NOT BE LEFT WITHIN CHILDREN'S REACH, AS THEY ARE POTENTIAL SOURCES OF DANGER. ▪ THE UNIT MUST ONLY BE USED BY ADULTS. DO NOT ALLOW CHILDREN TO TAMPER WITH OR USE THE PRODUCT.
	<ul style="list-style-type: none"> ▪ FIXTURE INSTALLATION WORK MUST BE CARRIED OUT BY EXPERIENCED QUALIFIED STAFF. ▪ AVOID USING THE FIXTURE IN LOCATIONS SUBJECT TO VIBRATIONS, OR POSSIBLE IMPACTS ▪ AVOID USING THE FIXTURE IN LOCATIONS IN WHICH THE TEMPERATURE IS ABOVE 45° OR BELOW 2°C ▪ DO NOT ATTEMPT TO DISMANTLE OR MODIFY THE FIXTURE. ▪ THE FIXTURE MUST BE KEPT AT A MINIMUM DISTANCE OF 1.5 METRES FROM SURFACES TO BE ILLUMINATED.
	<ul style="list-style-type: none"> ▪ IN THE EVENT OF SERIOUS PROBLEMS OR FAULTY OPERATION, SWITCH OFF THE FIXTURE AND IMMEDIATELY CONTACT THE NEAREST SGM TECHNICAL ASSISTANCE CENTRE OR CONTACT THE MANUFACTURER DIRECTLY. ▪ DO NOT OPEN THE FIXTURE: THERE ARE NO USER-REPAIRABLE PARTS INSIDE. ▪ NEVER TRY TO REPAIR THE FIXTURE PERSONALLY. REPAIRS CARRIED OUT BY UNAUTHORIZED STAFF CAN CAUSE DAMAGE OR FAULTY OPERATION. ALWAYS CONTACT THE NEAREST AUTHORIZED TECHNICAL ASSISTANCE CENTRE.

ALWAYS INSIST ON ORIGINAL SPARE PARTS BEING FITTED

General Warranty Conditions

- The unit is guaranteed for 12 months from the date of purchase against manufacturing faults of the unit or the material it is made from
- Faults or breakdowns caused by inexperienced or incorrect use of the unit are not covered by the guarantee
- The guarantee will be considered null and void if the unit has been opened or tampered with by unauthorized personal
- The guarantee does not foresee the replacement of the unit
- External components such as handles, switches and removable parts are excluded from the guarantee
- Transport costs and consequent risks are the responsibility of the unit's owner
- The validity of the guarantee is effective to all effects only on presentation of the guarantee to the manufacturer or the SGM technical assistance centre
- Always quote unit serial number and model when contacting the dealer for information or assistance



Disposing of this product

SGM products are supplied in compliance with Directive 2002/96/EC of the European Parliament and of the Council of the European Union on WEEE (Waste Electrical and Electronic Equipment), as amended by Directive 2003/108/EC, where applicable. Help preserve the environment! Ensure that this product is recycled at the end of its life. Your supplier can give details of local arrangements for the disposal of SGM products.

Protect the environment: don't throw packing material into your garbage can return it to your SGM retailer or take it to the nearest special waste collection point.

1 INTRODUCTION

1.1 Main Features

LEDs

Palco fixtures use LED (Light Emitted Diode) technology as a light source. A series of LED points mounted on a matrix enables to generate an evenly distributed light beam, suitable for illuminating large areas.

PALCO:

The three types of LED (Red, Green and Blue) that make up the matrix enable to realize and control any colour of light beam, with perfectly balanced colour at all times.

Palco's LED matrices are of two types, which identify the models:

- **Palco 3 with** LEDs of three Watts each
- **Palco 5 with** LEDs of five Watts each

PALCO WHITE:

Thanks to two different types of LEDs (White - Amber) forming the lighting sector, it is possible to accurately recreate the fluctuation and nuances of natural daylight.

There are two different types of Palco White LED lighting sectors, which identify two different models:

- **Palco 3 White** with 3W LEDs
- **Palco 5 White** con punti LED da cinque Watt ciascuno

LENSES

Each Palco LED is fitted with an interchangeable high efficiency lens. The lens matrices available enable to project light beams with the following projection angles:

- 8 °
- 25 °
- 40 °
- 10° x 22° horizontal
- 10° x 22° Vertical

FUNCTIONS

- **PALCO:** RGB colour mixing
PALCO WHITE: LED White and Amber for different temperatures colour of the light beam white
- Linear dimmer
- Shutter
- Adjustable strobe effects
- **PALCO:** Preset (on Macro) colour and rainbow effects
PALCO WHITE: different temperatures color of the light beam white man pre-programmed
- Setting via on-board microcomputer viewable on the unit's display
- Display "flip" function (rotates text through 180°)
- Adjustable display brightness
- LED power reduction in the event of overheating
- Elapsed time meter for each colour channel (Red, Green and Blue)
- General fixture operating time meter

CONTROL SIGNALS

- DMX 512 or RS 232 input signal
- Stand-alone operation with built-in programming
- Independent day to day control of the on-board programs on a weekly basis
- Independent operation of systems with up to 30 fixtures, via Master – Slave links

MICROCOMPUTER

- Fixture personalization according to the type of installation
- Test functions for each effect
- Fixture addressing via the unit's display
- Access menu for on-board programming functions
- Menus for access to calendar and event scheduling programming functions

1.2 *Palco functions*

USITT DMX 512

All the functions of Palco 3 and Palco 5 can be controlled via Usitt DMX 512 Standard serial digital signal, or RS 232 serial signal; Palco 5 has an integrated DMX wireless interface. Palco generates a proprietary data transmission protocol when Master-Slave self-controlled systems are created by on-board programming.

Palco requires six channels to control all its parameters. All the parameters are controlled and can be programmed by an integrated processor, MOTOROLA DSP 56F 803 for Palco 3, and DSP 56F805 for Palco 5.

COOLING

Palco 3 does not use any type of forced ventilation as cooling system, thus improving silent running and preventing the accumulation of dust or particles inside the projector. The radiator, installed on the back panel of the LED lighting sector, ensures the correct cooling by convection.

Palco 5 uses a forced ventilation system regulated by a software algorithm, which ensures a high degree of noiselessness.

An integrated temperature self-regulating system ensures continuous operation even in critical thermal conditions.

COLOUR

PALCO:

Three groups of Red, Green and Blue LEDs make up the matrix that generates Palco's light beam. Their layout in the matrix ensures that the emitted light can be controlled as far as Colour, Intensity and Temperature are concerned. Palco's colour generation system is therefore based on the concept of additive colour mixing, where the sum of the various intensities of Red, Green and Blue, (RGB) enables to create any other colour with the required tone or saturation.

PALCO WHITE:

Thanks to two different types of LEDs (White - Amber) forming the lighting sector, it is possible to accurately recreate the fluctuation and nuances of natural daylight.

The temperature of the white can be regulated without any light efficiency loss in a range from 2000°K to 6700°K approximately.

LEDs

The power of the LEDs making up the light source depend on whether the fixture is a Palco 3 or Palco 5

PALCO 5 has a light source formed by 5W K2 LEDs and generates a maximum luminosity of 4500 Lumens.

PALCO 3 has a light source formed by 3W and 1W LUXEON LEDs and reaches a luminosity of 2800 Lumens.

PALCO 5 WHITE has a light source formed by 5W K2 LEDs and generates a maximum luminosity of 4800 Lumens.

PALCO 3 WHITE has a light source formed by 3W LUXEON LEDs and reaches a luminosity of 3800 Lumens.

DIMMER

The electronic control of the luminous intensity of the LEDs ensures precise emission adjustment, without colour or colour temperature variation over the entire range from 0 to 100 %, in a regular uniform manner.

SHUTTER

The shutter control parameter ensures instant light beam opening and closing effects. The characteristics of the LEDs allow to obtain strobe effects with adjustable or random flash power and rate with exceptional precision and intensity, thanks to the lack of any mechanical form of beam blackout.

MACRO

The Macro parameter allows to select (via DMX) a series of preset on-board colour and dimmer (or combined) effects whenever they are required. Rainbow effects with different speeds and random or Colour-dimming and Color-strobe, can be enabled without having to be programmed beforehand.

The Macro parameter of Palco White enables to select -via DMX- different colour temperatures for the white light beam.

MEMORIES

Comprehensive programming can be carried on-board the fixture, thus enabling playback in a fully stand-alone status without the aid of external DMX control. It's also possible to program playback times and modes in the space of 24 hours, with a 7-day repetitive cycle.

Complete stand-alone systems can be realized, with absolutely no external controls and up to 30 fixtures; with operating times and modes programmed and controlled using Master/Slave connections.

Five shows, each made up of ten scenes can be programmed on each fixture.

DISPLAY

Palco has a 10-digit, 10x10 point matrix display for user-friendly navigation through the fixture's setting, diagnosis and programming menus. Flip, Dimm (brightness) and ON/OFF functions are available to facilitate consultation and use.

SOFTWARE UPDATE

The fixture's software can be updated from a Personal Computer via RS 232 serial or USB connector cable. (not included) Updating allows to improve the fixture's performance through time. Palco software will be available on the SGM web site.

1.3 Mechanical specifications

Fixture made up of a twin body: Base + Head.

The base is made up of a die-cast unit containing the power supply, display, three buttons and three watertight cable glands for mains supply and DMX cables.

The base is built for floor or wall mounting via screw plugs, has two Fast-Lock holes for fitting a clamp for truss mounting, and can also be floor-mounted (or on any other flat surface) without fixing, remaining steady no matter what the angle of the head.

The head is made up of a radiator (in drawn aluminium), on which the LED matrix and lenses are fitted. The head can be moved in relation to the base: PAN +/- 45° and TILT -75° (backwards) +15°(forwards). The head has stop screws to block PAN/TILT in the required positions.

Protected to:	Palco 3 / Palco 3 White	IP65
	Palco 5 / Palco 5 White	IP55

Material resistant to weather and any acts of vandalism (shatter-proof glass)

Dimensions:

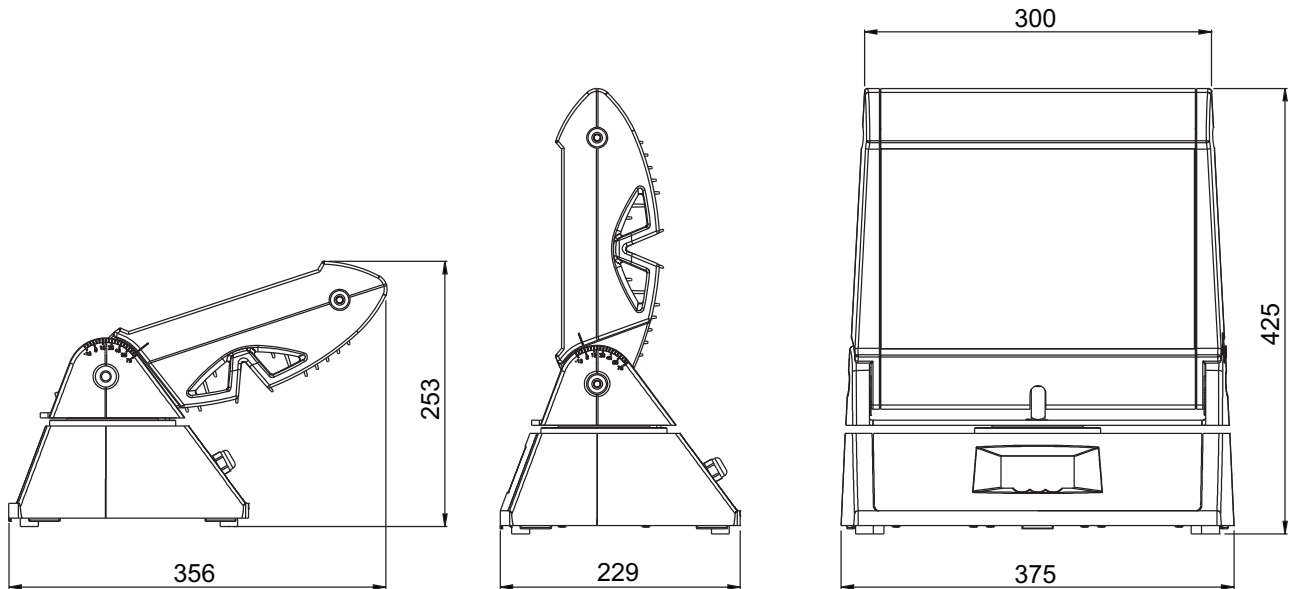

- Weight: 13,5 Kg

1.4 *Electrical specifications*

Palco 5

- Luminous power: 200 Watt
- Power absorbed: 240 Watt

Palco 3

- Luminous power: 100 Watt
- Power absorbed: 130 Watt

Palco 5 White

- Luminous power: 200 Watt
- Power absorbed: 240 Watt

Palco 3 White

- Luminous power: 120 Watt
- Power absorbed: 150 Watt

Full-range PFC power supply (does not distort the mains power supply): 90-270V AC, 50-60 Hz

User interface: LED display 1x10 alphanumerical digits, panel with three buttons.

LENSES

Lenses mounted on an interchangeable plate (all the lenses are in a single block) with various beam apertures:

- 8°
- 25°
- 40°
- 10° x 22° horizontal or vertical asymmetrical beam

LEDs

Palco 5

- 12 Blue K2 LEDs 4,5 Watts
- 24 Green K2 LEDs 4,5 Watts
- 13 Red K2 LEDs 4,5 Watts

Palco 3

- 7 Blue Luxeon LEDs 3 Watts
- 18 Green Luxeon LEDs 3 Watts
- 24 Red Luxeon LEDs 1 Watt

Palco 5 White

- 13 Amber K2 LEDs 3 Watt
- 36 White K2 LEDs 4,5 Watt

Palco 3 White

- 18 Amber Luxeon LEDs 3 Watt
- 31 White Luxeon LEDs 3 Watt

1.5 *Optional Accessories*

- 8° front lens
- 25° front lens
- 40° front lens
- 10° x 22° horizontal front lens
- 10° x 22° vertical front lens

2 INSTALLATION



2.1 Unpacking the fixture

Before installing the fixture, make sure that the packing contains the items indicated in the following list and the fixture has not been damaged.

In case of doubts, do not use the fixture and contact an SGM authorised assistance service centre and the transportation company. The consignee only can claim for damages to the fixture caused during transportation.

- 1 Palco projector Mod. 3 or 5
- 6mm UNI 6 setscrew wrench
- 3 mm UNI 67 setscrew wrench
- PG9 black threaded plug
- NIC brass counter nut
- ORM 0130-15 O-ring seal
- Display cover
- User manual

DO NOT DESPERD THE PACKING ELEMENTS.

THE PACKING ELEMENTS (PLASTIC BAGS, FOAM, NAILS, ETC.), MUST NEVER BE LEFT NEAR CHILDREN, AS DANGEROUS. USE THE ORIGINAL PACKAGE IN CASE OF FIXTURE RETURN TO THE MANUFACTURER FOR REPAIR OR MAINTENANCE SERVICE, IT HAS BEEN SPECIFICALLY MADE TO PROTECT THE FIXTURE DURING THE TRANSPORT.

2.2 Mounting the fixture

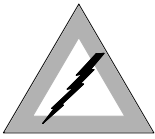

ATTENTION!

Before installing the fixture, make certain the AC mains cable is disconnected.

WIRING

Being a fixture protected to IP65, the unit is already fitted with wiring and dedicated cable gland. Palco only requires its AC plug to be wired, following the indications below:

Simbolo	Pin	EU	US	UK
L	Live	Brown	Yellow/Copper	Red
N	Neutral	Blue	Silver	Black
	Ground	Yellow/Green	Green	Green



ATTENTION!

- Wiring and connection work must be carried out by experienced qualified staff.
- Class one equipment must be earthed (grounded)
- Do not power Palco units with dimmers, as this could damage their on-board power supply
- Before connecting the unit, make certain that the mains power supply is the same as indicated on the fixture's ID plate
- The unit must be protected by a thermal/magnetic circuit-breaker

Palco is controlled via DMX 512 serial digital signal. Cables for connection to the signal (supplied) are fitted with standard XLR 5-Pin connectors. It is indispensable to use cables that meet EIA RS-485 specifications to connect the fixtures to the control console.

INSTALLATION AND POSITIONING

Palco is an automated colour-changing fixture suitable for use in decorative/architectural and show lighting. The type of installation can therefore be varied according to its use.

Palco can be permanently mounted, in the case of fixed installations, by means of the four holes on its base, using the M6 screws as shown in the diagram. The distance between the holes is 180 mm on the front and 204.5 mm on the side.

It's also possible to fit a display safety cover to avoid any unauthorized use of the front control panel.

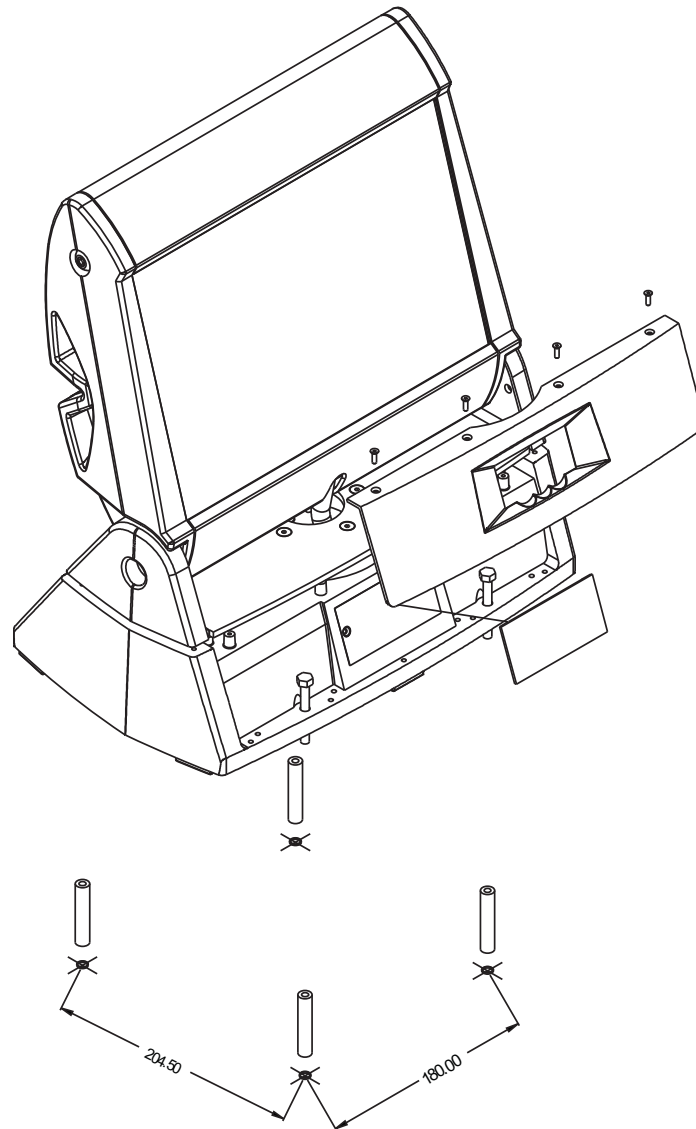

The display cover is fitted as follows:

- Loosen the hex screws fixing the horizontal positioning bracket using the 3 mm. key provided
- Turn the bracket 45° to uncover the top fixing screws of the front panel
- Remove the first two screws with a Phillips screwdriver (not supplied)
- Turn the head's horizontal positioning bracket -45° until the other two front panel screws can be seen
- Remove the last two screws with a Phillips screwdriver (not supplied)
- Now remove the front panel
- Fit the protective cover to the display
- Replace the front panel again, following the procedure described above

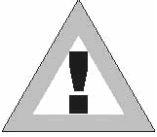
**ATTENTION!**

- Do not install the fixture near naked flames
- Do not install the fixture near inflammable liquids
- Avoid violent impacts or conditions in which the unit is subject to continuous vibrations
- Install the unit in a ventilated location



The Palco can be hung on any support or truss structure using Fast-Lock "G" or "Aliscaff" clamps. In the event of an Aliscaff-type clamp being used, a Fast-Lock Omega support must be used as shown in the diagram.

There are no indications against using any particular the position for the clamps in the fixture's base.

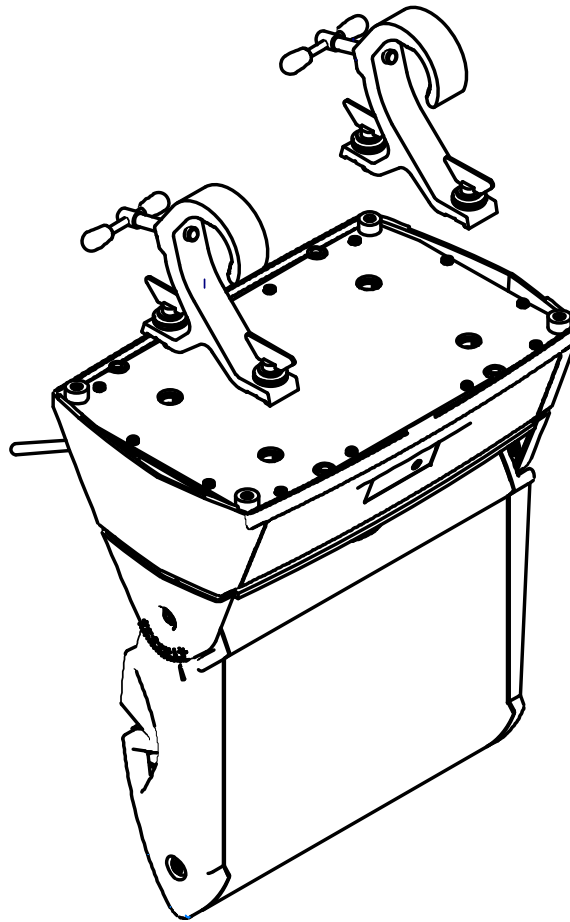
**ATTENTION!**

If the fixture is suspended from a truss suspended above ground or floor level, fix the fixture with a steel safety cable.

Palco can be panned through + or - 45° and tilted -75° (backwards) and +15° (forwards). The required movement is fixed by means of the screws on the head support, as shown in the diagram. The hex keys for fixing PAN and TILT are supplied with the fixture and are (respectively) 6 mm. and 3 mm. keys

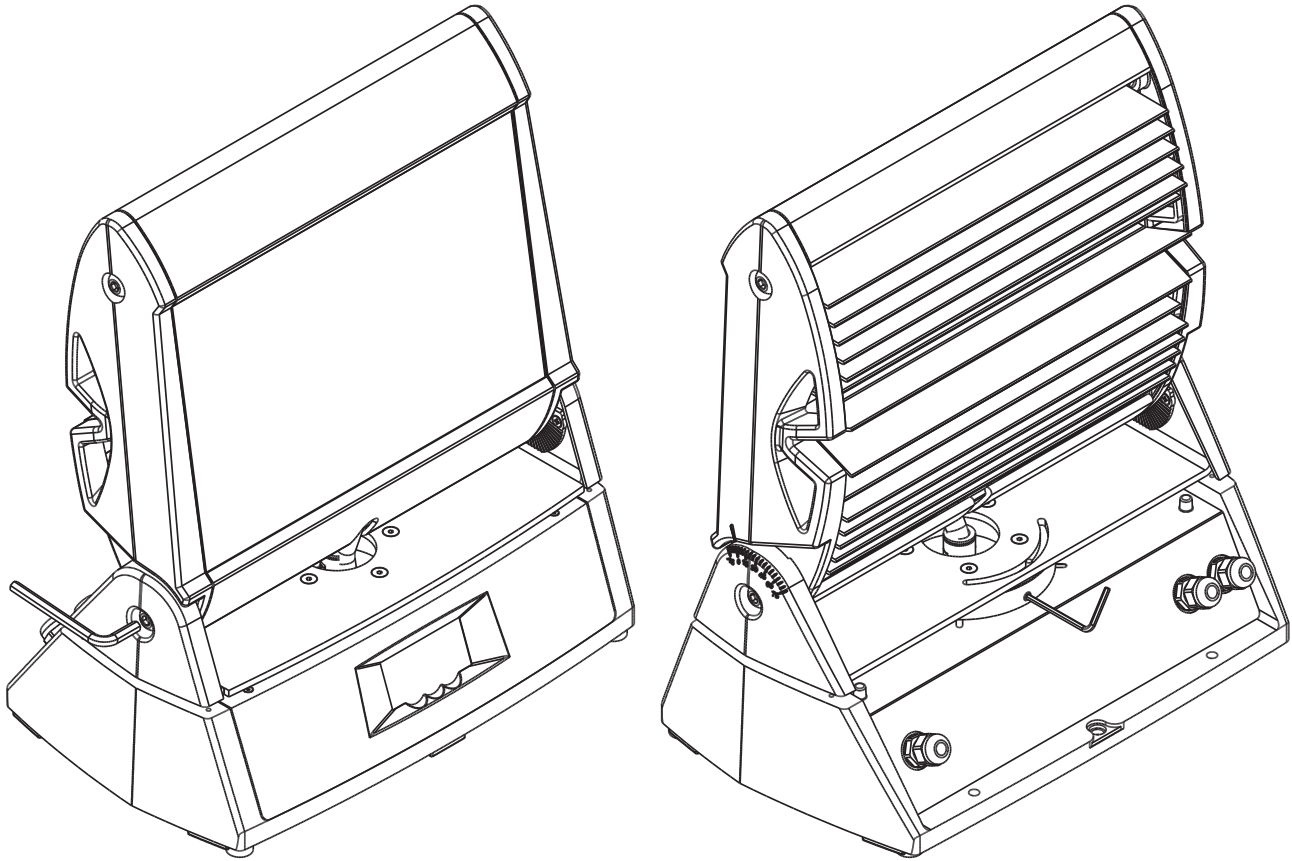

ADDRESSING THE FIXTURE

Palco 3 and Palco 5 are fitted with an on-board microcomputer, which enables them to be configured and addressed for the control of their programming.

There are two fundamental modes in which the units can operate:

Controlled via DMX by an external console

Stand-alone Mode with on-board programming and the possible control of a series of other fixtures using a MASTER-SLAVE set-up.

We'll now cover the addressing of a Palco for DMX control using an external console. Stand-Alone mode on the other hand is covered in the "Stand-alone Programming chapter"

Once the fixture is switched on, its name appears in the display (PALCO 3 or PALCO 5) along with the version of the software installed on the microcomputer (e.g.: 1.0). As soon as the start-up sequence is finished, "ADDR = 1" will appear on the display, showing that the fixture is addressed to DMX channel 1.

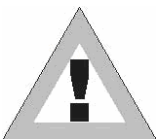

ATTENTION!

If the flashing message NO SIGNAL or SIGNAL ERROR appears, this means that the fixture is not receiving a DMX signal from the Console or is receiving an incorrect signal.

To change the DMX address, proceed as follows:



Press the UP key. The message Addr=1 will appear

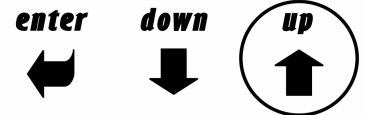

Press Enter and "Addr=" will begin to flash

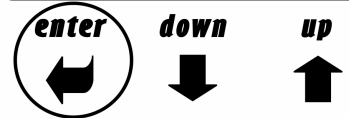
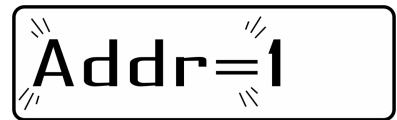

Use the UP and Down arrow keys to choose the required address channel

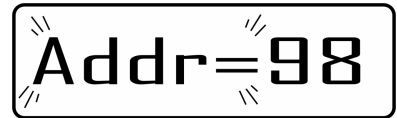

Press Enter again to confirm

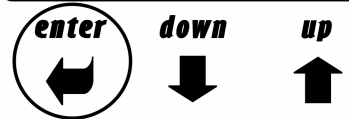
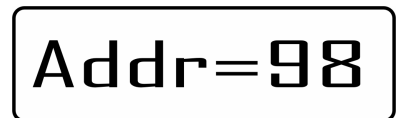

Palco requires 8 DMX channels for the control of all its functions. With a DMX 512 control universe, up to 64 can therefore be controlled simultaneously and separately



ATTENTION!

Do not use more than 25 fixtures on any one DMX line! Should it be necessary to connect a larger number of fixtures, the appropriate Buffers or Splitter must be used for each 25 fixtures, to ensure that the signal quality remains unchanged.

Check the following table to see the exact DMX address for each fixture connected on the same DMX line.

PALCO N°	ADDRESS DMX	PALCO N°	ADDRESS DMX	PALCO N°	ADDRESS DMX	PALCO N°	ADDRESS DMX	PALCO N°	ADDRESS DMX
1	001	13	097	25	193	37	289	49	385
2	009	14	105	26	201	38	297	50	393
3	017	1	113	27	209	39	305	51	401
4	025	16	121	28	217	40	313	52	409
5	033	17	129	29	225	41	321	53	417
6	041	18	137	30	233	42	329	54	425
7	049	19	145	31	241	43	337	55	433
8	057	20	153	32	249	44	345	56	441
9	065	21	161	33	257	45	353	57	449
10	073	22	169	34	265	46	361	58	457
11	081	23	177	35	273	47	369	59	465
12	089	24	185	36	281	48	377	60	473

3 OPERATION



3.1 Controlling the fixture via DMX

The following table shows the control channels of the Palco 3 and Palco 5 and relative on-board patch.

Canale DMX	Function		Description
	Palco	Palco White	
Ch 1	Shutter/Strobe	Shutter/Strobe	Shutter and strobe functions are adjustable and random. Pulse Functions
Ch 2	Dimmer	Dimmer	Luminous intensity control
Ch 3	Red	White1	Continuous Red saturation control 0-100% / White1
Ch 4	Green	White2	Continuous Green saturation control 0-100%/ White2
Ch 5	Blue	Amber	Continuous Blue saturation control 0-100%/ Amber
Ch 6	CTC	CTC	Continuous colour temperature control
Ch 7	Macro	Macro	Macro functions
Ch 8	Mod_Colore	Mod_Colore	White balance control

DIMMER CHANNEL CH 2

DMX Value	Mean Value	Function
0 - 255		Linear intensity adjustment 0 - 100 %

RED CHANNEL CH 3

DMX Value	Mean Value	Function
0 - 255		Linear Red saturation adjustment 0 - 100 %

GREEN CHANNEL CH 4

DMX Value	Mean Value	Function
0 - 255		Linear Green saturation adjustment 0 - 100 %

BLUE CHANNEL CH 5

DMX Value	Mean Value	Function
0 - 255		Linear Blue saturation adjustment 0 - 100 %

STROBE/SHUTTER CHANNEL CH 1

DMX Value	Mean Value	Function
0 - 7		Shutter closed
8 - 15		Shutter open
16 - 151		Linear Strobe frequency adjustment from 1 to 20 Hz
152 - 159		Pulse open effect low speed
160 - 167		Pulse open effect medium speed
168 - 175		Pulse open effect high speed
176 - 183		Pulse close effect low speed
184 - 191		Pulse close effect medium speed
191 -199		Pulse close effect high speed
200 - 207		Random strobe effect low speed
208 - 215		Random strobe effect medium speed
216 - 223		Random strobe effect high speed
224 - 255		Shutter open

MACRO CHANNEL CH 7

PALCO			PALCO WHITE		
DMX Value	Mean Value	Function	DMX Value	Mean Value	Function
0 - 7	4	NO MACRO	0 - 7	4	NO MACRO
8 - 15	12	MACRO 1 Rainbow Slow - Stand Time 5 sec	8 - 15	12	MACRO 1 White ~3000°K
16 - 23	20	MACRO 2 Rainbow Medium - Stand Time 5 sec	16 - 23	20	MACRO 2 White ~3200°K
24 - 31	28	MACRO 3 Rainbow Fast - Stand Time 5 sec	24 - 31	28	MACRO 3 White ~4000°K
32 - 39	36	MACRO 4 Rainbow Slow - NO Stand time	32 - 39	36	MACRO 4 White ~5000°K
40 - 47	44	MACRO 5 Rainbow Medium - NO Stand time	40 - 47	44	MACRO 5 White ~5600°K
48 - 55	52	MACRO 6 Rainbow Fast - NO Stand time	48 - 55	52	MACRO 6 White ~6500°K
56 - 63	60	MACRO 7 Rainbow VerySlow - NO Stand time	56 - 63	60	MACRO 7 White ~6700°K
64 - 70	68	MACRO 8 Random Color Slow	64 - 70	68	Future
71	71	Store Color_mode enable	71	71	Store Color_mode enable
72 - 79	76	MACRO 9 Random Color Medium	72 - 79	76	Future
80 - 87	84	MACRO 10 Random Color Fast	80 - 87	84	Future
88 - 95	92	Future	88 - 95	92	Future
96 - 103	100	Future	96 - 103	100	Future
104 - 111	108	Future	104 - 111	108	Future
112 - 119	116	Future	112 - 119	116	Future
120 - 136	128	Future	120 - 136	128	Future

COLOUR MODE CHANNEL CH 8

DMX Value	Mean Value	Function
0 - 63	32	White balance disabled (Full Colour)
64 - 189	127	White balance enabled (Balanced)
190 - 250	220	White balance disabled (Full Colour)
251 - 255	253	Store a new white balance

CTC CHANNEL CH 6

DMX Value	Mean Value	Function
0 - 19	10	OFF
20 - 255	138	From Cold + 2000 K° to Warm - 2000 k° compared to balanced white or not

3.2 Operation

COLOURS

Palco 3 and Palco 5 are fitted with a white balancing system that can be customized and stored for each fixture for an unlimited number of times. Moreover, in the context of any balance which is set, it's possible also possible to adjust colour temperature in a completely dynamic manner according to needs, by means of the CTC channel, with a certain range round the balanced white or Full Colour value.

All these operations can be carried out via DMX, or directly on the fixture itself. Should it be necessary to balance the white via DMX, proceed as follows:

1. Set the Color_Mode channel at 220 (85%)
2. Use the RED, GREEN and BLUE channels to obtain the required white balance
3. Set the Macro channel at 71 (28%)
4. Increase Color_Mode to the maximum - 255 (100 %). After 4 seconds, the new white balance is stored by the Palco

The Color Mode channel can also be used as an instant selector between: previously stored balance (at the value of 127) or Full-color Power (at the value of 0) when total colour emission is required, without any limits being set by the balance.

COLOUR TEMPERATURE

The CTC channel allows to adjust Palco's colour temperature. It acts in a range around the white balance or Full-Color, according to requirements. It's therefore possible to cool or heat in a linear manner absolutely any type of previously chosen white by more or less 2000 K°

SHUTTER/STROBO

The Shutter/Strobe channel allows an endless number of shutter effects to be achieved. As well as the adjustable frequency strobe effect (from 1 Hz to 20 Hz), it's possible to create Random-Strobe effects at three different speeds. Low - Medium - High). Palco is also fitted with a Pulse Open and Close effect for each of the three different speeds (Low - Medium - High)

4 MICRO COMPUTER CONTROL

4.1 *Microcomputer "Control"*

Palco is fitted with a microcomputer that enables the best fixture customization to the type of installation. It is possible:

- To assign the starting address
- Run diagnostic checks controlling the correct functioning of the fixture
- Customization of some of the parameters
- Stand-Alone programming

4.2 *Navigating the menu*

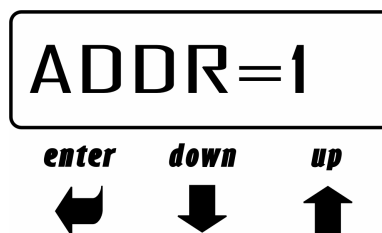

The front control panel made of a display and three keys give an easy access to all the available settings of Genio Mobile.

- UP/DOWN KEYS:

Are used to scroll the various items in the menu. In the selected menu, they are used to change the required parameters.

- ENTER KEY:

Is used to access to the selected menu and, once the necessary changes have been made, is used to confirm them.

4.3 Structure of the Menu

This chapter covers all the functions that can be accessed by the microcomputer's menus. These functions allow to set the fixture according to one's needs, obtain information on its operation, test its various parts and lastly program it, if it has to be used in Stand-alone mode.

The Up and Down keys on the front control panel enable users to scroll through the various menu items. In the selected menu, they enable to modify the necessary parameters.

The ENTER key gives access to the selected menu, and once the necessary modifications have been carried out, enables changes to be confirmed.

Menu		Option	Description
Palco 5 Palco 5 White	Palco 3 Palco 3 White		
Addr	Addr	001 - 504	Fixture addressing
COLBALANCE	COLBALANCE	-	It enables to have access to the setup functions for white balancing
BALANCE	BALANCE	ON	It activates the white balancing of the COLBALANCE menu
		OFF	It deactivates the white balancing of the COLBALANCE menu
	BOOST (no White LED)	ON	It activates the power boost
		OFF	It deactivates the power boost
R_h	R_h	-	Red LED operating hours menu. Reset is possible
G_h	G_h	-	Green LED operating hours menu. Reset is possible
B_h	B_h	-	Blue LED operating hours menu. Reset is possible
L_h	L_h	-	Overall fixture operating hours menu
SIGN	SIGN	DMX	DMX selected signal
		RS 232	RS 232 selected signal
WIRELS		ON	It enables the wireless reception of the DMX signal
		OFF	It disables the wireless reception of the DMX signal
LOGOFF		SET	It deactivates the previous wireless settings
W_EXIT		ON	It enables the output of the wireless signal on the DMX OUT port
		OFF	It disables the output of the wireless signal on the DMX OUT port
BRIGH	BRIGH	100 - 53 - 40 - 27 - 20 13 - 6 - 0 (%)	It enables to change the brightness of the display Default configuration = 40 %
DSPLFLIP	DSPLFLIP	-	It inverts the display reading orientation
DMXDLY	DMXDLY	0 - 998 (sec) - UNL	It is possible to set the time in seconds to maintain the last status of the fixture channels without DMX signal (default = UNL)
		UNL	It always maintains the last status of the channels even without DMX signal
DAY	DAY	MON - TUE - WED - THU - FRI - SAT- SUN	It sets the day of the week
C	C	Hh : mm : ss	It sets the time, minutes and seconds of the internal clock
FACT	FACT	SET	It enables to set the fixture default parameters
		OFF	FACT value during normal operation

PREV	PREV	SET	It enables to reset the values of the parameters set immediately before the FACT=SET operation
		OFF	PREV value during normal operation
TEST	TEST	-	It tests the correct operation of the fixture physical channels depending on the selection
TEMPERATUR	TEMPERATUR	-	It shows the actual temperature of the head in Celsius or Fahrenheit
MASTER	MASTER	ON	Fixture in Master data transmission mode
		OFF	Fixture in non-Master mode
SLAVEID	SLAVEID	1 - 39	It configures the slave number assigned to the fixture
SCHEDL	SCHEDL	ON	It enables the playback of the programs according to the schedule
		OFF	It disables the playback of the programs according to the schedule
PRGRUN	PRGRUN	OFF	It disables the playback of the programs
		1 - 5	It enables the playback of one of the five programmes
PROGAMMER	PROGAMMER	-	It enables to have access to the programming functions of the five programmes
SCHEDULER	SCHEDULER	-	access to the programming of the Scheduler
ADDR	ADDR		Display default status after 8 seconds of pause

ADDRESSING

This menu gives access to fixture addressing functions. See Installation – Addressing Chapter)

Addr=xxx

1. Use the UP/DOWN keys to find the "Addr" menu
2. Press "Enter" to confirm the choice. The text on the display will begin to flash.
3. Use the UP/DOWN keys to select the required start channel.
4. Press "Enter" to confirm the choice.

COLOUR BALANCE

This menu gives access to the setting of Palco's white balance. If it's necessary to work with a fixed colour temperature, this menu must be used.

COLBALANCE

Rblnc=60%

Gblnc=100%

Bblnc=98%

1. Use the UP/DOWN keys to find the "COLBALANCE" menu
2. Press "Enter" for approximately six seconds.
3. "Rblnc=100%" will appear on the display and the Palco will switch on at maximum RGB values
4. Press "Enter" again and "Rblnc=" will begin to flash
5. Use the UP/DOWN keys to adjust the new maximum value required for the Red channel.
6. Press "Enter" to confirm the choice.

1. Use the UP key to select "Gblnc=100%"
2. Press "Enter" again and "Gblnc=" will begin to flash
3. Use the UP/DOWN keys to adjust the new maximum value required for the Green channel.
4. Press "Enter" to confirm the choice.

WHITE LED:

Wlblnc=60%

W2blnc=100%

Abblnc=98%

1. Use the UP key to select "Bblnc=100%"
2. Press "Enter" again and "Bblnc=" will begin to flash
3. Use the UP/DOWN keys to adjust the new maximum value required for the Blue channel.
4. Press "Enter" to confirm the choice.
5. Press "Enter" for approximately six seconds to exit the COLORBALANCE menu.

BALANCE

The "Balance" menu allows to enable or disable the white balance, previously set using the COLORBALANCE menu

BALANC=0N

1. Use the UP/DOWN keys to find the "BALANC=OFF" menu
2. Press "Enter" and the displayed text will immediately begin to flash
3. Use the UP/DOWN keys to choose ON or OFF status
4. Press "Enter" to exit the BALANC menu

BOOST

The Boost menu allows to choose 2 different operating modes for the LEDs that make up the Palco. When enabled, Boost allows an overall increase of 30% in the power flow emitted.

BOOST=ON

1. Use the UP/DOWN keys to find the "BOOST=OFF" menu
2. Press "Enter" and the displayed text will immediately begin to flash
3. Use the UP/DOWN keys to choose ON or OFF status
4. Press "Enter" to exit the BOOST menu

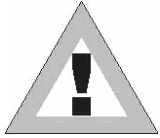

ATTENTION !!

Enabling BOOST means halving the overall lifespan of the LEDs by approximately. 100,000 to 50,000.

ELAPSED TIME METER

This menu gives access to the display of running time of the single channels (Red, Green and Blue).

It's also possible to reset the elapsed time meter when the LED matrix is replaced. The "L_h" menu gives access to the display of the fixture's total operating time and can't be reset

R_h=278

1. Use the UP/DOWN keys to find the "R_h" menu to display the operating time of all the Red LEDs

R_h=0

Resetting the Elapsed Time Meter:

1. hold the ENTER key pressed down for approx. 6', until R_h flashes
2. Use the UP/DOWN keys to find set the elapsed time meter at zero
3. Press "ENTER" to confirm

Use the same procedure for "G_h" (Green) and "B_h" (Blue).

INPUT SIGNAL

This function allows to choose which type of input signal is to be used: DMX 512 or RS-232.

SIGN=DMX

1. Use the UP/DOWN keys to find the "Sign=DMX" menu
2. Press "Enter" to confirm the choice. The text on the display will begin to flash.
3. Use the UP/DOWN keys to select the type of signal to be used.
4. Press "Enter" to confirm the choice.

WIRELESS

Palco 5 with the DMX Wireless connection as standard. It uses a technology based on the idea of GSM, with a radius over 500 meters. It has been widely tested in environments with WiFi, bluetooth, GPRS-UMTS signals, with excellent results.

WIRELS

To enable the wireless communication proceed as follows:

- Palco 5 has two menu for the: 1-WIRELESS LOG OFF and 2-WIRELESS.
- The procedure to activate the wireless communication is very easy:
 1. Enter the LOGOFF menu and confirm the SET option. This function disables all the communications previously activated
 2. Set the WIRELS menu on ON. This will enable a new communication.
 3. Press the LOG key on the Transmitter to connect the receiver located on the fixture.

WIRELESS LOGOFF

LOGOFF

This function allows to disable all the wireless communication previously activated.

To enable the LOGOFF, proceed as follows:

1. Connect Palco 5 to the power supply, wait till it has completed reset operations.
2. Use the UP/DOWN keys to find the "WIRELESS LOGOFF" menu.
3. Press ENTER to confirm. The message on the display will start to flash.
4. Use the UP/DOWN keys to confirm the SET option.
5. At this point Palco 5 is set for a WIRELESS communication

WIRELESS EXIT

W_EXIT

This function enables or disables the wireless signal output on DMX OUT port:

1. Connect Palco 5 to the power supply; wait until the reset operations are completed.
2. the UP/DOWN keys, select the menu "W_EXIT".
3. Press the "Enter" key to confirm the selection. The words on the display will start to flash.
4. Using the UP/DOWN keys, select ON if you want to enable the output of the wireless signal on the DMX OUT port, or select OFF if you want to confirm the SET option.

DISPLAY BRIGHTNESS

Operators can select one of the brightnesses available for the Palco (standard or very low). This option was included for theatre and television use, where excessive brightness can be disturbing. To adjust display brightness, proceed as follows:

BRIGHT=40%

1. Use the UP/DOWN keys to find the "Bright" menu
2. Press "Enter" to confirm the choice. The text on the display will begin to flash.
3. Use the UP/DOWN keys to select the required option from those available.
4. Press "Enter" to confirm the changes.

INVERT DISPLAY

When the fixture is suspended "upside down" from a structure, the operator can turn the text on the display through 180°, thus enabling the menus available to be easily read.

To change the reading angle, proceed as follows:

DSPL FLIP

1. Use the UP/DOWN keys to find the "Dspl Flip" menu
2. Press "Enter" to confirm the choice. The text on the display will begin to flash.
3. Use the UP/DOWN keys to select the required option.
4. Press "Enter" to confirm the changes.

DMX DELAY

It's possible to decide for how many seconds the fixture must hold the last operating status if there is no DMX signal. "Delay" time can be set between 0 and 998 seconds. If set at UNL, the fixture will hold its standby status for an unlimited time. This function is indispensable in the event of the DMX signal being accidentally interrupted. To set the required time, proceed as follows:

DMXDLY=20

1. Use the UP/DOWN keys to find the "DMXDLY" menu
2. Press "Enter" to confirm the choice. The text on the display will begin to flash.
3. Use the UP/DOWN keys to select the required length of time. If UNL (unlimited) is set, the last valid operating status is held no matter for how long the DMX signal is missing.
4. Press "Enter" to confirm the changes.

DAYS OF THE WEEK

It is of fundamental importance to set the day of the week on the Palco if it has to be used later in Stand-alone mode.

DAY=TUE

1. Use the UP/DOWN keys to find the "DAY" menu
2. Press "Enter" to confirm the choice. The text on the display will begin to flash.
3. Use the UP/DOWN keys to select the current day of the week.
4. Press "Enter" to confirm.

TIME

It's just as important to set Palco's on-board clock if it has to be used later in Stand-alone mode.

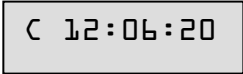

1. Use the UP/DOWN keys to find the "C" (Clock) menu
2. Press "Enter" to confirm the choice. The first two numbers (relative to the hours) will begin to flash on the display.
3. Use the UP/DOWN keys to select the current time (the hour – from 00 to 23).
4. Press "Enter" to move the setting from the hours to the minutes
5. Use the UP/DOWN keys to select the current time (the minutes – from 00 to 59).
6. Press "Enter" to move the setting from the minutes to the seconds
7. Use the UP/DOWN keys to select the current time (the seconds – from 00 to 59).
8. hold "Enter" pressed down for approx. 6sec. to confirm the new time

SETTING DEFAULT PARAMETERS

This enables to set the default parameters

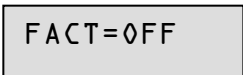
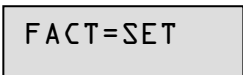

1. Use the UP/DOWN keys to find the "FACT" menu
2. Press "Enter" to confirm the choice. The text on the display will begin to flash.
3. Use the UP/DOWN keys to select "FACT=SET" and press "Enter"
4. Press "Enter" to set the default parameters shown in the table. "FACT=OFF" appears on the display.

PALCO3	PALCO 5	MENU ITEM	DEFAULT PARAMETER
X	X	ADDR	001
X	X	BRIGHT	40%
X	X	DMXDLY	UNL
X		BOOST	OFF
	X	WIRELS	OFF
	X	W_EXIT	OFF

RESETTING DEFAULT PARAMETERS

This enables to reset the parameter values set immediately before the FACT=SET operation. In other words, if the default parameters have been set by mistake, this operation allows to revert to the values set previously.

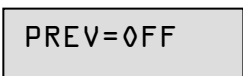
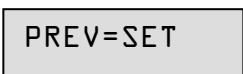

1. Use the UP/DOWN keys to find the "Prev" menu
2. Press "Enter" and hold it down for a few seconds to confirm the choice. The text on the display will begin to flash.
3. Use the UP/DOWN keys to select "PREV=SET"
4. Pressing "Enter" in this mode resets the values, cancelling the FACTORY DEFAULT operation. In the meanwhile, PREV stops flashing and the message that appears is PREV=OFF

TEST FUNCTIONS

Using the test menu, it's possible to test the correct operation of the channels that control the Palco.

TEST=BLUE

1. Use the UP/DOWN keys to find the "TEST" menu
2. Press "Enter" and hold it down for a few seconds to confirm the choice. The text on the display will begin to flash.
3. Use the UP/DOWN keys to select the physical channel to be tested (ALL - SHUTT - DIMMR - RED - GREEN - BLUE - CTC)
4. Press "Enter" and the selected text will begin to flash, running a test routine on the chosen channel.
5. Press "Enter" again to exit the routine being run and choose another channels to be tested
6. Keep "Enter" pressed down for a few seconds if you wish to exit the TEST menu

TEMPERATURA

Using the TEMPERATUR menu it is possible to display the actual temperature. Palco 3 indicates only the temperature of the head of the fixture, while Palco 5 indicates also the temperature of the fixture base. In case of critical heat conditions, it is very important to know the temperature of Palco, as the unit is provided with a LED self-protection system which reduces the overall power emission when Palco is operating at too high temperatures.

TEMPERATUR

HEAD=21°C

BASE=21°C

1. Using the UP/DOWN keys, select the menu "TEMPERATUR"
2. Press the "Enter" key to instantaneously display the actual temperature
3. Using the UP/DOWN keys, it is possible to display the temperature in Celsius or Fahrenheit
4. Press "Enter" to quit the TEMPERATUR menu

CONFIGURING A MASTER

When a system with several interconnected fixtures has to be used in Stand-alone mode, there has to be one MASTER fixture, able to control the other fixtures, via appropriate on-board programming.

MASTER=0N

1. Use the UP/DOWN keys to find the "MASTER" menu
2. Press "Enter" and the displayed text will immediately begin to flash
3. Use the UP/DOWN keys to choose ON or OFF status
4. Press "Enter" to exit the MASTER menu

CONFIGURING SLAVES

When a system with several interconnected fixtures has to be used in Stand-alone mode, there has to be one MASTER fixture, whereas each of the fixtures controlled by it must be individually configured with its own SLAVE number. In the event of the same ID being used for several fixtures, they will not be able to be controlled individually by the MASTER program.

SLAVEID=12

1. Use the UP/DOWN keys to find the "SLAVEID" menu
2. Press "Enter" and the displayed text will immediately begin to flash
3. Use the UP/DOWN keys to choose the required ID (from 1 to 29)
4. Press "Enter" to exit the SLAVEID menu and confirm

ENABLING – DISABLING THE SCHEDULER

The Scheduler allows to organize and run the fully automatic playback of a series of Events on a weekly basis, including the preset programs on the MASTER fixture. The Scheduler is enabled as follows:

SCHEDL=0N

1. Use the UP/DOWN keys to find the "SCHEDL" menu
2. Press "Enter" and the displayed text will immediately begin to flash
3. Use the UP/DOWN keys to choose ON or OFF status
4. Press "Enter" to exit the SCHEDL menu and confirm

INTERNAL PROGRAM PLAYBACK

Each fixture can be programmed with 5 Programs of 10 scenes each. The programs are enabled using the PRGRUN menu

PRGRUN=3

1. Use the UP/DOWN keys to find the "PRGRUN" menu
2. Press "Enter" and the displayed text will immediately begin to flash
3. Use the UP/DOWN keys to choose the required programs from 1 to 5, or OFF to stop the playback of a current program.
4. Press "Enter" to exit the PRGRUN menu and confirm.

PROGRAMMER

The Programmer menu allows to carry out Palco's on-board programming for any stand-alone operation without external DMX control. The "Programmer" menu also allows to program a maximum of 29 SLAVE fixtures connected to the MASTER fixture with the on-board programming.

The fundamental stages of the Palco's programming are as follows:

1. Entering the "PROGRAMMER" menu
2. Choosing the Program number
3. Choosing the scene number
4. Choosing the number of Slaves (if any) involved in the scene
5. Setting scene parameters
6. Choosing the scene times
7. Choosing the fade times
8. Optional scene disabling and enabling

The "Stand-Alone Programming" chapter describes all the operations necessary.

SCHEDULER

The Scheduler menu gives access to the programming of “events” able to run the playback of programs previously prepared on-board the Palco, with the necessary times and modes. There are 48 events and each one can control the start and stop time of a program day by day on a weekly basis.

The fundamental stages of programming the Scheduler are as follows:

1. Entering the Scheduler menu
2. Choosing the event number
3. Choosing the program number
4. Choosing the day,
5. hours and minutes of the event’s start
6. hours and minutes of the event’s end
7. Optional event disabling and enabling

The “Stand-Alone Programming” chapter describes all the operations necessary for Scheduler programming in detail.

5 STAND-ALONE PROGRAMMING

In permanent installations for architectural use, it may be necessary to use Palco fixtures in Stand-Alone mode (with independent operation). This is very useful when the fixture has to run relatively simple scenes over a period of time, without the aid of an external DMX controller, which could be difficult for inexperienced staff to operate. The simplification of Palco's operation ensures greater flexibility of use, even with important installations of a decorative-architectural nature. Each Palco can therefore be programmed by means of 10 Programs, each with 10 scenes which are completely adjustable as far as times and modes are concerned.

The "Scheduler" section also allows to organize the playback of programs already prepared on a weekly basis (day by day from Monday to Sunday), deciding the start and finish time of playback of the Program. Each day can obviously contain several events, for a maximum of 48 per week.

Should the installation involve a large number of fixtures, it's possible to create a completely independent programmable MASTER-SLAVE type system, which can involve a maximum of 30 fixtures. In this case, it will only be necessary to program the MASTER (main) fixture, and all the fixtures connected to it will run the same program if configured as SLAVES. During Master programming, it's also possible to store various luminous statuses for several fixtures within each scene of the program. Each on-board Master program is therefore also able to individually control all the SLAVE fixtures scene by scene.

Everything is obviously controllable by means of the Scheduler, which enables the system controller to automate all the events as required over a period of time without having to resort to external controllers every time.

5.1 Programming PALCO

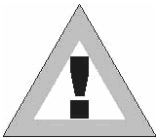

ATTENTION !

Palco programming is possible if the fixture isn't receiving a DMX 512 or RS 232 signal.

Make certain that the fixture is not receiving DMX 512 or RS 232 signals and configure Palco as a "MASTER" (see. "Master Configuration" in the previous chapter).

Follow the steps described now for the programming:

MASTER

Once Master status is enabled, "MASTER" appears on the display.

STEP 1 - SCELTA CHOOSING THE PROGRAM NUMBER

PROGRAMMER

1. Use the UP/DOWN keys to find the "PROGRAMMER" menu
2. Press "Enter" for a few seconds, until the following appears: "PROGRAM=1"

PROGRAM=1

3. If it is necessary to create a program other than number 1, press "Enter" again and "PROGRAM=" will begin to flash
4. Use the UP/DOWN keys to choose the required program number from 1 to 5, then Press "Enter" to exit the PROGRAM menu and confirm.

STEP 2 - CHOOSING THE SCENE NUMBER

SCENE=1

1. Use the UP key to pass to the "SCENE=1" menu
2. If it is necessary to create a program other than number 1, press "Enter" again and "SCENE=" will begin to flash
3. Use the UP/DOWN keys to choose the required scene number from 1 to 5, then Press "Enter" to exit the SCENE menu and confirm..

STEP 3 - CHOOSING THE FIXTURE NUMBER

FIXT=ALL

FIXT=0DD

FIXT=EVEN

FIXT=MASTR

FIXT=SLV12

1. Use the UP key to pass to the "FIXT=ALL" menu
2. Press "Enter" and "FIXT=" will begin to flash
Use the UP/DOWN keys to choose:
 - "ALL" if the scene to be created involves all fixtures (MASTER + SLAVES).
 - "MSTR" if the scene to be created involves just the Master fixture.
 - "ODD" if the scene to be created involves the odd-numbered fixtures.
 - "EVEN" if the scene to be created involves the even-numbered fixtures.
 - "SLV1" - "SLV29" if the scene to be created must have each slave fixture with its own channel status, chosen individually
3. Press "Enter" to exit the FIXTURE menu and confirm.

STEP 4 - SHUTTER

SHUTT=100%

1. Use the UP key to pass to the "SHUTT=100%" menu
2. Press "Enter" and "SHUTT=" will begin to flash
3. Use the UP/DOWN keys to choose the required value of the shutter channel for the current scene.
4. Press "Enter" to exit the SHUTTER menu and confirm.

STEP 5 - DIMMER

DIMMR=100%

1. Use the UP key to pass to the "DIMMR=100%" menu
2. Press "Enter" and "DIMMR=" will begin to flash
3. Use the UP/DOWN keys to choose the required value of the dimmer channel for the current scene.
4. Press "Enter" to exit the DIMMER menu and confirm.

STEP 6 - RED / WHITE1

RED=50 %

WHIT1=50 %

1. Use the UP key to pass to the "RED=0 %" menu
2. Press "Enter" and "RED=" will begin to flash
3. Use the UP/DOWN keys to choose the required value of the COLOUR-Red channel for the current scene.
4. Press "Enter" to exit the RED menu and confirm.

STEP 7 – GREEN / WHITE2

GREEN=70 %

WHITE2=70 %

1. Use the UP key to pass to the "GREEN=0 %" menu
2. Press "Enter" and "GREEN=" will begin to flash
3. Use the UP/DOWN keys to choose the required value of the COLOUR-Green channel for the current scene.
4. Press "Enter" to exit the GREEN menu and confirm the menu GREEN e confermare.

STEP 8 – BLUE / AMBER

BLUE=100%

AMBER=100%

1. Use the UP key to pass to the "BLUE=0 %" menu
2. Press "Enter" and "BLUE=" will begin to flash
3. Use the UP/DOWN keys to choose the required value of the COLOUR-Blue channel for the current scene.
4. Press "Enter" to exit the BLUE menu and confirm.

STEP 9 – MACRO

In the program, it's possible to use scenes with effects pre-programmed in the Macro channel. Wherever Macros are used, all the colour channel settings will be ignored.

MACRO=4

1. Use the UP key to pass to the "MACRO=0" menu
2. Press "Enter" and "MACRO=" will begin to flash
3. Use the UP/DOWN keys to choose the required Macro value for the current scene.
4. Press "Enter" to exit the MACRO menu and confirm.

STEP 9 - SCENE TIME

Each scene in a program can be run with the required times. There are two types of scene times:

- Total scene time (STIME), expressed in hours, minutes and seconds
- Scene fade time (FTIME), expressed in hours, minutes and seconds

The scene time is the total time occupied by the scene in the program, whereas fade time is the time taken by the scene's channel status to reach the appropriate level.

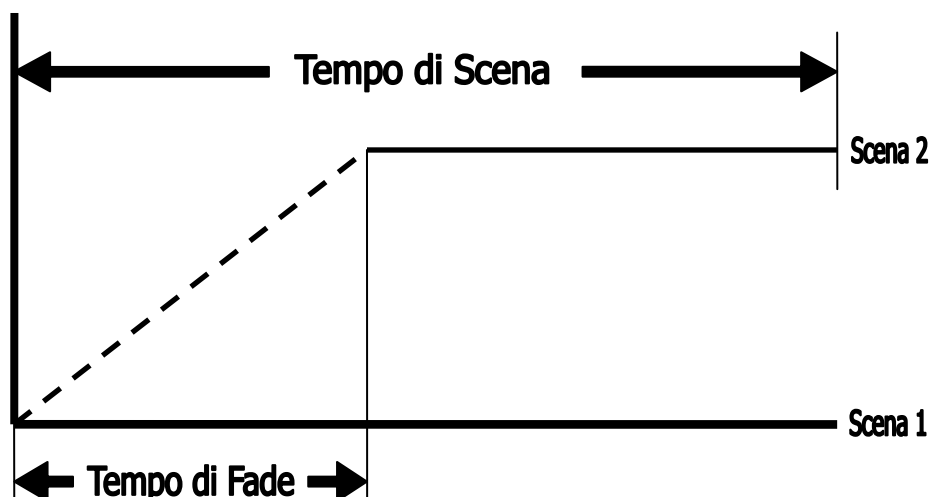

The STIME menu gives access to the adjustment of the total scene time. The time can be configured in hours, minutes and seconds.

STIME_h=2

1. Use the UP key to pass to the "STIME_h=0" menu
2. Press "Enter" and "STIME_h=" will begin to flash
3. Use the UP/DOWN keys to choose the number of hours the current scene has to last.
4. Press "Enter" to exit the "STIME_h" menu and confirm.

STIME_m=10

1. Use the UP key to pass to the "STIME_m=0" menu
2. Press "Enter" and "STIME_m=" will begin to flash
3. Use the UP/DOWN keys to choose the number of minutes the current scene has to last.
4. Press "Enter" to exit the "STIME_m" menu and confirm.

STIME_s=30

1. Use the UP key to pass to the "STIME_s=0" menu
2. Press "Enter" and "STIME_s=" will begin to flash
3. Use the UP/DOWN keys to choose the number of seconds the current scene has to last.
4. Press "Enter" to exit the "STIME_s" menu and confirm

STEP 10 - FADE TIME

The FTIME menu gives access to the adjustment of the scene fade time. The time can be configured in hours, minutes and seconds.

FTIME_h=0

1. Use the UP key to pass to the "FTIME_h=0" menu
2. Press "Enter" and "FTIME_h=" will begin to flash
3. Use the UP/DOWN keys to choose the number of hours of the current scene's fade time.
4. Press "Enter" to exit the "FTIME_h" menu and confirm.

FTIME_m=3

1. Use the UP key to pass to the "FTIME_m=0" menu
2. Press "Enter" and "FTIME_m=" will begin to flash
3. Use the UP/DOWN keys to choose the number of minutes of the current scene's fade time.
4. Press "Enter" to exit the "FTIME_m" menu and confirm.

FTIME_s=0

1. Use the UP key to pass to the "FTIME_s=0" menu
2. Press "Enter" and "FTIME_s=" will begin to flash
3. Use the UP/DOWN keys to choose the number of seconds of the current scene's fade time.
4. Press "Enter" to exit the "FTIME_s" menu and confirm.



ATTENTION !!

The program does not display the scene if its scene time is ZERO.

If the scene time is less than the fade time, the scene will not reach its value, but will be cut along the fade time when the scene time finishes.

STEP 11 - ENABLING SCENES

Enabling a scene decides if the scene will be run or not when the program is run. The SCNRUN menu is also useful when it is necessary to temporarily eliminate the playback of some scenes in a program without cancelling them.

SCNRUN=0N

1. Use the UP key to pass to the "SCNRUN=OFF" menu
2. Press "Enter" and "SCNRUN=" will begin to flash
3. Use the UP/DOWN keys to choose ON to enable the scene, or OFF if it has not to be run.
4. Press "Enter" to exit the SCNRN menu and confirm.

Repeat the above steps to program other scenes on the Palco.

Once programming is finished, keep "Enter" pressed down for approximately 6 sec. In order to exit the PROGRAMMER menu.

STEP 12 - PROGRAM PLAYBACK

To start the playback of a program, access the PRGRUN menu

PRGRUN=1

1. Use the UP/DOWN keys to find the "PRGRUN" menu
2. Press "Enter" and the displayed text will immediately begin to flash
3. Use the UP/DOWN keys to choose the required programs from 1 to 5, or OFF to stop the playback of the current program.
4. Press "Enter" to exit the PRGRN menu and confirm.

5.2 *The Event Scheduler*

Scheduler is a Palco menu that allows to organize a series of 48 events over a period of a week and which are repeated week after week. Each event can control the day and time of the start and finish of one of the ten programs already prepared on board the Palco, in order to automate playback, without the need for any external operators.



ATTENTION!

Before proceeding with the programming of the Scheduler, it's important to set the current date and time (See Chap. Menu - paragraph: Days of the week and time

STEP 1 - CHOOSING THE EVENT NUMBER

SCHEDULER

EVENT=1

1. Use the UP/DOWN keys to find the "SCHEDULER" menu
2. Press "Enter" for a few seconds, until the following appears: "EVENT=1"
3. If it is necessary to create a event other than number 1, press "Enter" again and "EVENT=" will begin to flash
4. Use the UP/DOWN keys to choose the required event, from 1 to 48, then Press "Enter" to exit the EVENT menu and confirm..

STEP 2 - CHOOSING THE PROGRAM NUMBER

PROGRAM=5

1. Use the UP key to pass to the "PROGRAM=1" menu
2. Press "Enter" and "PROGRAM=" will begin to flash
3. Use the UP/DOWN keys to choose the required program number (from 1 to 5) to be controlled by Scheduler.
4. Press "Enter" to exit the PROGRAM menu and confirm

STEP 3 - CHOOSING THE DAY

DAY=FRI

1. Use the UP key to pass to the "DAY=MON" menu
2. Press "Enter" and "DAY=" will begin to flash
3. Use the UP/DOWN keys to choose the day of the week on which the event must begin. The days of the week are expressed as follows:
 - ALL Every day
 - MON Monday
 - TUE Tuesday
 - WED Wednesday
 - THU Thursday
 - FRIFriday
 - SAT Saturday
 - SUN Sunday
4. Press "Enter" to exit the DAY menu and confirm.

STEP 4 - START TIME

START TIME is used to configure: the hour, minutes and seconds in which an event containing a previously prepared program will start.

START_h=21

START_m=15

START_s=30

1. Use the UP key to pass to the "START_h=0" menu
 2. Press "Enter" and "STIME_h=" will begin to flash
 3. Use the UP/DOWN keys to choose the hour at which the program has to start (from 0 to 23)
 4. Press "Enter" to exit the "START_h" menu and confirm.
-
1. Use the UP key to pass to the "START_m=0" menu
 2. Press "Enter" and "START_m=" will begin to flash
 3. Use the UP/DOWN keys to choose the minutes at which the program has to start (from 0 to 59)
 4. Press "Enter" to exit the "START_m" menu and confirm.
-
1. Use the UP key to pass to the "START_s=0" menu
 2. Press "Enter" and "START_s=" will begin to flash
 3. Use the UP/DOWN keys to choose the seconds at which the program has to start (from 0 to 59)
 4. Press "Enter" to exit the "START_s" menu and confirm.

STEP 5 - END TIME

END TIME is used to configure: the hour, minutes and seconds in which an event containing a previously prepared program will end.

END_h=23

1. Use the UP key to pass to the "END_h=0" menu
2. Press "Enter" and "END_h=" will begin to flash
3. Use the UP/DOWN keys to choose the hour at which the program has to end (from 0 to 23)
4. Press "Enter" to exit the "END_h" menu and confirm.

END_m=30

1. Use the UP key to pass to the "END_m=0" menu
2. Press "Enter" and "END_m=" will begin to flash
3. Use the UP/DOWN keys to choose the minutes at which the program has to end (from 0 to 59)
4. Press "Enter" to exit t.

END_s=30

1. Use the UP key to pass to the "END_s=0" menu
2. Press "Enter" and "END_s=" will begin to flash
3. Use the UP/DOWN keys to choose the seconds at which the program has to end (from 0 to 59)
4. Press "Enter" to exit the "END_s" menu and confirm.

STEP 6 - ENABLING AN EVENT

ENABLE=0N

1. Use the UP key to pass to the "ENABLE=OFF" menu
2. Press "Enter" and "ENABLE=" will begin to flash
3. Use the UP/DOWN keys to choose ON to enable the event, or OFF if it is to be disabled.
4. Press "Enter" to exit the "ENABLE" menu and confirm.

Repeat the above steps to program other events on the Palco.

Once programming is finished, keep "Enter" pressed down for approximately 6 sec. In order to exit the SCHEDULER menu.

STEP 7 - ENABLING THE SCHEDULER

To start the scheduler and all its "Actions", it's necessary to enter the SCHEDL=ON menu

PRGRUN=1

1. Use the UP/DOWN keys to find the "SCHEDL=ON" menu
2. Press "Enter" and SCHEDL= will immediately begin to flash
3. Use the UP/DOWN keys to choose ON or OFF, according to requirements
4. Press "Enter" to exit the SCHEDL=ON menu and confirm.

6 MAINTENANCE



ORDINARY MAINTENANCE

Palco does not require much maintenance work, so it must be remembered:

- To avoid operating the unit in unsuitable conditions and clean it externally, particularly in permanent outdoor installations, where objects and material can deposit on it through time. (e.g. leaves and/or rubbish of various kinds). The Palco head's rear radiator must be used in the best possible conditions in order to dispel heat and ensure the unit's good operation.
- Also periodically clean the front glass, particularly if the unit is exposed to the weather.
- Should the fixture remain unused for a lengthy period, the clock data may be lost. In this case, the internal clock must be reset.

SPECIAL MAINTENANCE

Special maintenance work is required in the following cases:

- Breakage of one or more LEDs
- External damage to the shell caused by violent impacts
- Breakage of the front glass or any other part that compromises the unit's protection rating
- Breakdowns in the fixture's on-board electronics

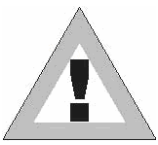
**ATTENTION:**

Do not attempt to repair the fixture. Only authorized staff can work on solving the type of problems mentioned above.
Contact the nearest SGM assistance centre in the event of special maintenance work being required

7 ACCESSORIES

7.1 *Installing optional lenses*

Palco can be fitted with various types of front lenses, in order to obtain different beam aperture angles. The following procedure must be followed in the event of the front lenses having to be changed on the LED matrix

REMOVING THE FRONT LENS PANEL

Remove the screws on the rear of the Palco's head (used to fix the head's top edge to its bottom edge), using a 3mm. hex key

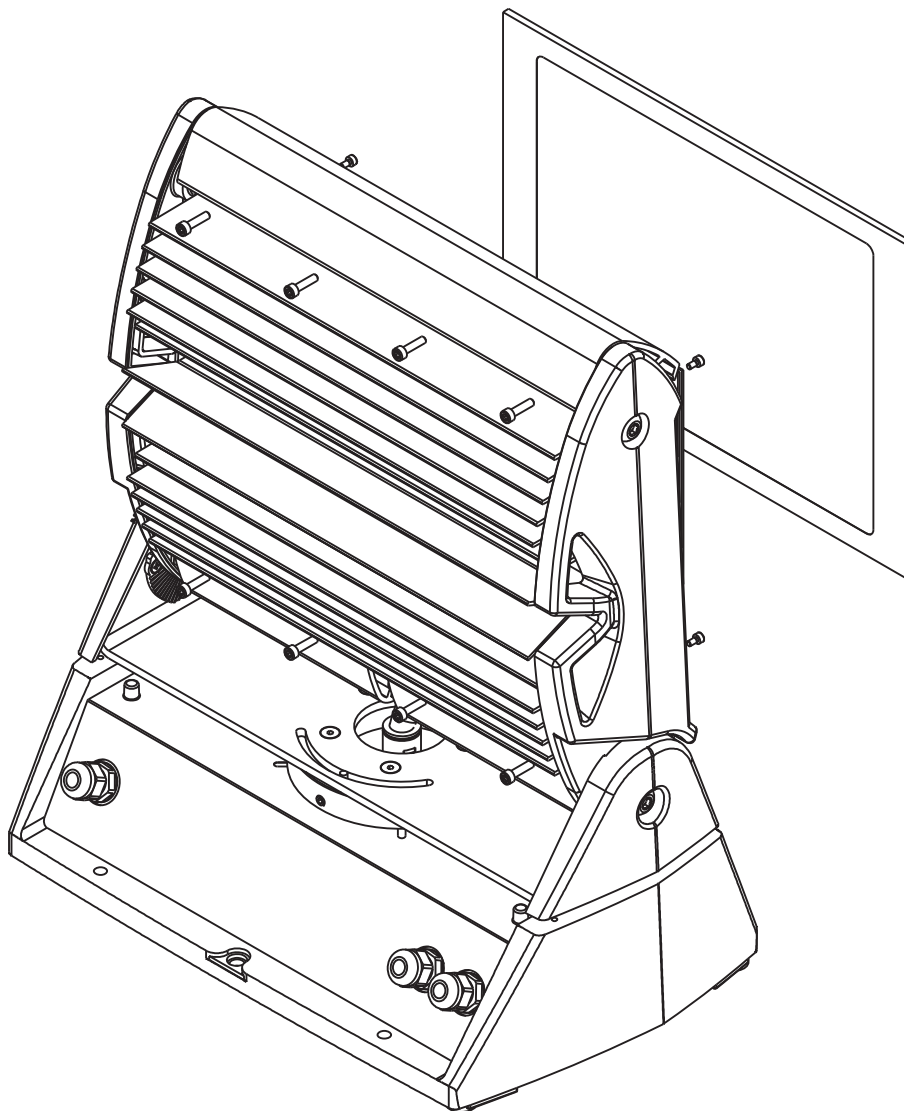

Rotating the two shells toward the front of the fixture, the front glass can be removed for access to the lens-holder panel.

Now loosen the 8 hex screws that fix the lens-holder panel to the LED matrix, aligned below, using a 2.5mm. key.

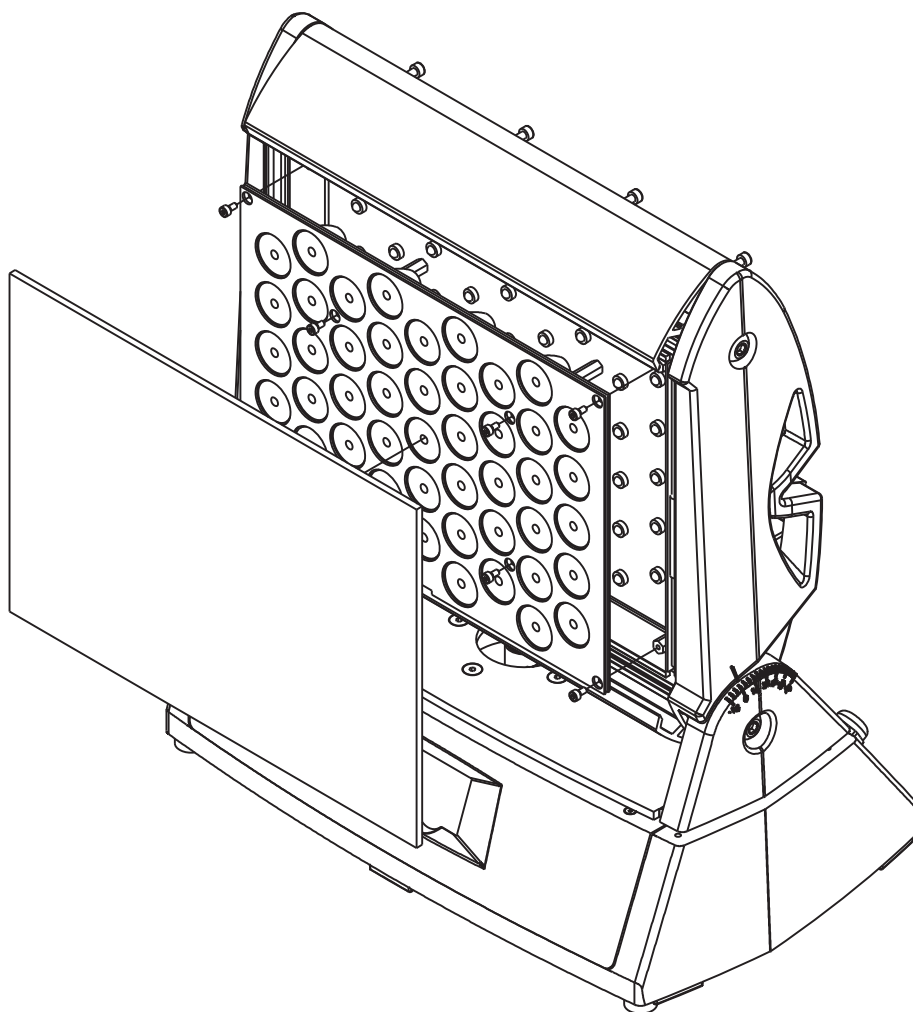

To install the new set of lenses, proceed as follows.
Carefully avoid touching the single lenses that make up the set. Should this happen, clean it/them carefully with a soft dry cloth.

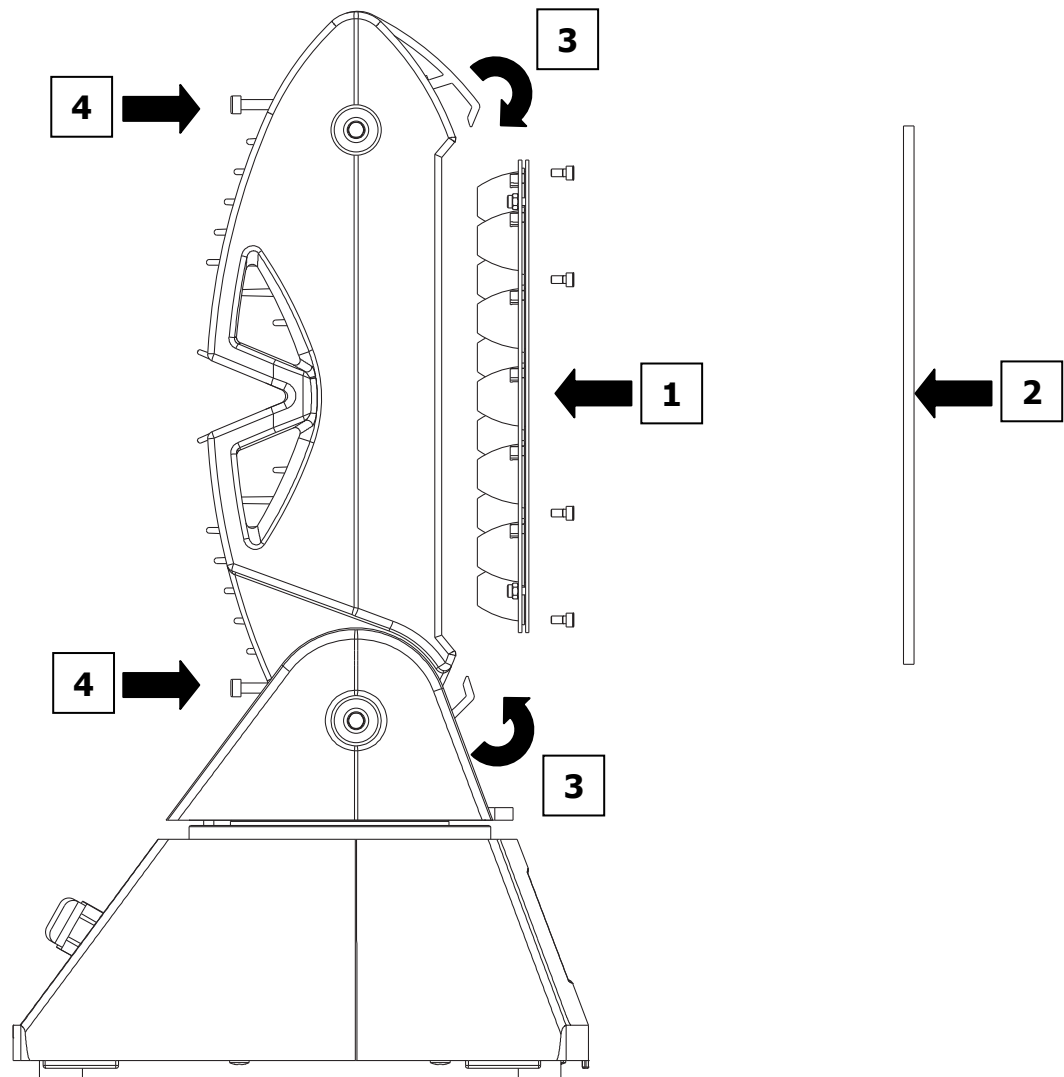
INSTALLING THE NEW FRONT LENS PANEL

1 Carefully position the new set of lenses, paying particular attention to the alignment of the LEDs in relation to the lenses.

**ATTENTION !**

before positioning the new set of lenses, carefully clean the LEDs with a soft dry cloth. CAREFULLY AVOID TOUCHING THE LEDs – should this occur, clean them with a dry cloth, under no circumstances using solvents, products for removing grease, or abrasive objects.

Once the new set of lenses is positioned, fix it to the matrix with the appropriate screws, without tightening them individually, but following an orderly sequence, progressively tightening them in one after another.

2 Replace the front glass, after having cleaned it with a soft dry cloth.

3 Close the 2 (top and bottom) shells of the head, ensuring that the front glass is evenly closed between them.

4 Fix the two shells with the appropriate rear screws.

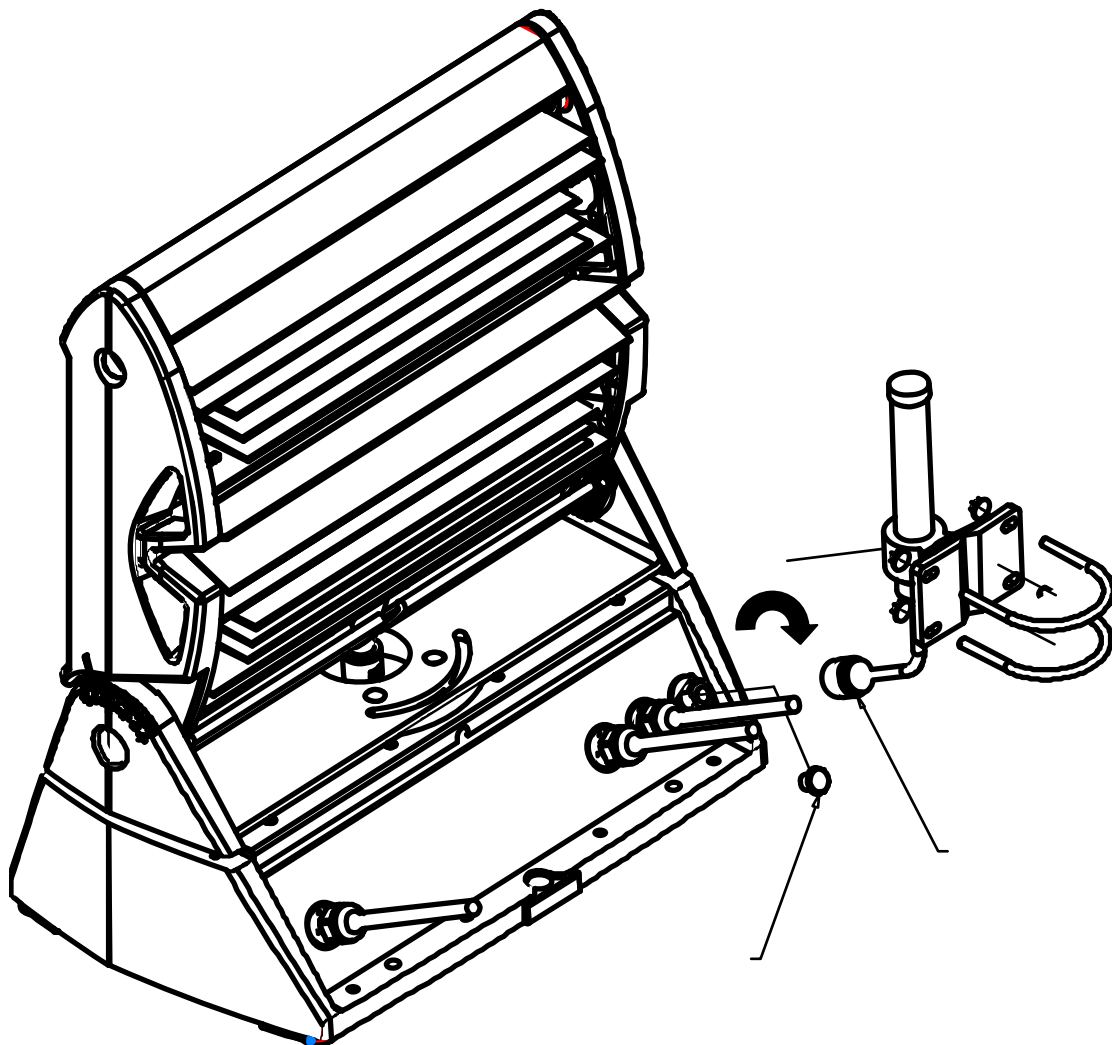
WIRELESS ANTENNA INSTALLATION FOR PALCO5

- 1** Remove the protection plug (A) from the wireless socket
- 2** Screw on the socket the ring (B) nut of the extension cable
- 3** Screw the antenna on the extension cable 3
- 4** Fix the antenna with the hook



SGM TECHNOLOGY FOR LIGHTING SPA
VIA PIO LA TORRE, 1_61010 TAVULLIA (PU), ITALY
TEL. +39 0721 476477 - FAX +39 0721 476170
www.sgm.it - info@sgm.it

